

FlowSell™
SELF-FEED SHELF SYSTEMS



DRINK FLOW RACKING

6 Railway Avenue
Huntingdale Vic 3166
Australia

Phone: +61 3 9568 1977
Fax: +61 3 9568 3521

Email: john@flowsell.com.au
Web: www.flowsell.com.au

™Trade Mark - Patent Granted



**FAST
EASY
RELAY
DIVIDERS**

DRINK FLOW RACKING

Main Benefits

- » **Sell more** from cool room shelves permanently faced up... all day, every day
- » **Save more** because cool room shelves require less maintenance and labour costs are lower
- » **Making you more profit**

Other Benefits

- » Drinks remain faced up even at rush hour
- » Providing a superior presentation to flat wire shelves
- » For easier customer identification and access
- » Dividers are adjustable for any bottle or can size
- » Single items can be ranged next to carton packs
- » Rear loading allows fast, easy re-stocking
- » Products do not spread out when stocking
- » Puts more stock on the shelf, not on the floor
- » Staff spend less time in the cool room
- » Staff spend more time with customers

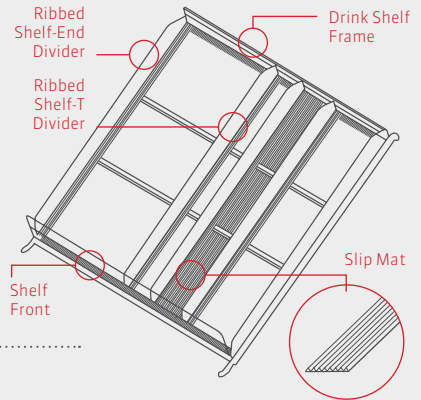

Sizes and Specifications

Drink Rack Frame

| Height | Width | Depth |
|--------|-------|-------|
| 2.1M | 760mm | 620mm |

Rack FlowShelf

| Width | Depth |
|-------|-------|
| 760mm | 570mm |

Finish Zinc Plated and Black Powder Coated

Ribbed Shelf-T Divider

570 Black

Ribbed Shelf-End Divider

570 Black

Slip Mats

Energy, 390ml, 600ml, 1.25L, 2L
Black

Shelf Fronts

60, 80, 100, 120mm high
Clear Acrylic (Wire for Milk)

Function

Ideal for gravity feeding Coke, Cadbury Schweppes, Sports Drinks, Energy Drinks, Waters, Juices, White and Flavoured Milk

