

**FLOWSELL™
SELF-FEED SHELF SYSTEMS**



LIQUOR FLOW RACKING

6 Railway Avenue
Huntingdale Vic 3166
Australia

Phone: +61 3 9568 1977
Fax: +61 3 9568 3521

Email: john@flowsell.com.au
Web: www.flowsell.com.au

™Trade Mark - Patent Granted



**FAST
EASY
RELAY
DIVIDERS**

LIQUOR FLOW RACKING

Main Benefits

- » **Sell more** from cool room shelves permanently faced up... all day, every day
- » **Save more** because cool room shelves require less maintenance and labour costs are lower
- » **Making you more profit**

Other Benefits

- » Liquor remains faced up even at rush hour
- » Providing a superior presentation to flat wire shelves
- » For easier customer identification and access
- » Dividers are adjustable for any bottle or can size
- » Single items can be ranged next to carton packs
- » Rear loading allows fast, easy re-stocking
- » Product does not spread out when stocking
- » Puts more stock on the shelf, not on the floor
- » Staff spend less time in the cool room
- » Staff spend more time with customers

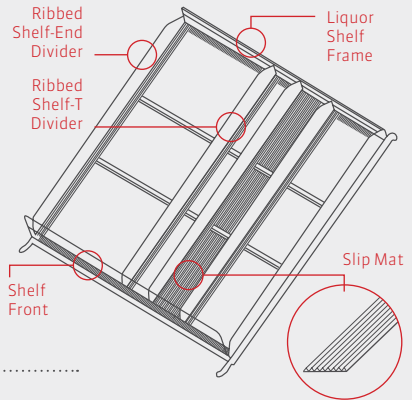

Sizes and Specifications

Liquor Rack Frame

Height	Width	Depth
2.1M	760mm	620mm

Rack FlowShelf

Width	Depth
760mm	570mm

Finish Zinc Plated and Black Powder Coated

Ribbed Shelf-T Divider

570 Black

Ribbed Shelf-End Divider

570 Black

Slip Mats

Long necks only
Black

Shelf Fronts

60, 80, 100, 120mm high
Clear Acrylic

Function Ideal for gravity feeding Wine, RTD's, Beer, Spirits and Beverages

